

**HAMM** & Co  
GmbH

34513 Waldeck 1

# Drallregler

mit el. Stellantrieb

Ausgabe: 4.14

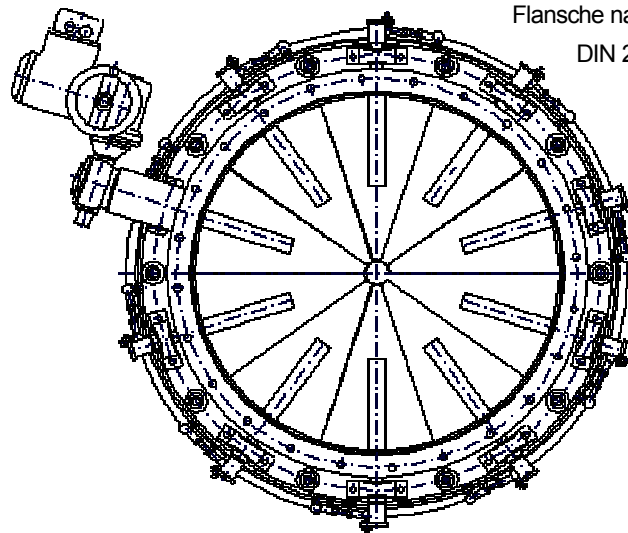

Flansche nach

DIN 24 154/R2/T2

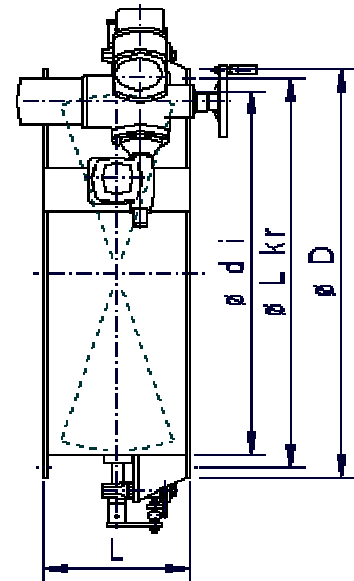

NW Ø D	L mm	Gewicht ohne Stellantrieb [kg]	Flanschmaße			erf. Stelmom./ kraft Nm / N	Preis, ohne Antrieb €	Vorschlag z.B. ARIS
			D	L Kr	d i			
<b>250</b>	180	33	323	292	253	18 / 200	<b>1.781,-</b>	NL 20
<b>280</b>	180	38	363	332	283	20 / 215	<b>1.910,-</b>	NL 40
<b>315</b>	200	45	398	366	318	22 / 230	<b>2.606,-</b>	NL 40
<b>355</b>	200	50	438	405	358	30 / 250	<b>3.462,-</b>	NL 40
<b>400</b>	200	58	484	448	404	35 / 280	<b>3.586,-</b>	NL 40
<b>450</b>	225	70	534	497	454	40 / 300	<b>3.693,-</b>	NL 60
<b>500</b>	225	95	584	551	504	60 / 350	<b>3.690,-</b>	NL 100
<b>560</b>	225	110	664	629	564	80 / 380	<b>3.701,-</b>	NL 100
<b>630</b>	315	130	734	698	634	95 / 400	<b>3.791,-</b>	NL 100
<b>710</b>	315	160	814	775	714	100 / 450	<b>3.910,-</b>	NL 120
<b>800</b>	315	180	904	861	804	150 / 500	<b>4.369,-</b>	KA 1518
<b>900</b>	400	200	1004	958	904	190 / 700	<b>4.794,-</b>	KA 1518
<b>1000</b>	400	260	1105	1067	1005	220 / 900	<b>5.205,-</b>	KA 1518
<b>1120</b>	400	350	1245	1200	1125	300 / 1100	<b>5.512,-</b>	KA 1518
<b>1250</b>	500	460	1375	1337	1255	350 / 1200	<b>6.084,-</b>	KA 1518
<b>1400</b>	500	500	1525	1491	1405	410 / 1300	<b>7.142,-</b>	KA 1518
<b>1600</b>	500	680	1725	1663	1605	500 / 1350	<b>8.312,-</b>	KA 1518
<b>1800</b>	560	820	1925	1856	1805	630 / 1500	<b>10.623,-</b>	KA 1518
<b>2000</b>	560	960	2125	2073	2005	800 / 2000	<b>11.844,-</b>	KA 3025
<b>2240</b>	600	1290	2385	2325	2245	/ 2300	<b>13.740,-</b>	KA 3025

Mehrpreise:

Stellantrieb-Anbau:

bis NW : bei frachtfreier Anlieferung

Ø 500: 176 .- €

Ø 1120: 195 .- €

Ø 1600: 370 .- €

&gt;Ø 1600: 580 .- €